



TRANE[®]

TRANE
TECHNOLOGIES

REFERENCE DESIGN #504

HIGH-EFFICIENCY COOLING FOR THE 1GW AI FACTORY

Scalable Thermal Infrastructure System
Design featuring Air-Cooled Magnetic
Bearing Chillers

A reference design engineered to simplify
operations and boost energy efficiency.





INTRODUCTION

Artificial intelligence is driving massive growth in data center demand — and advanced cooling is critical to keep innovation running. Trane leads the way with proven thermal management solutions for AI factories and data centers of all sizes.

This reference design provides:

- ✓ A 1GW cooling blueprint for AI factory applications
- ✓ Integrated air- and liquid-cooling configurations for NVIDIA racks
- ✓ Guidance on CDUs, fan coil walls, chillers, pumps and facility piping
- ✓ A foundation for mechanical design that complements electrical and controls systems





DESIGN OVERVIEW

Temperature and Flow Rates

This table summarizes temperature and flow rate requirements for the air-cooled chillers in this reference design. These values represent an AI factory installed in Albuquerque, NM and can be adjusted for specific applications.

Technical Loop Supply Temperature: 30°C (86°F)

Technical Loop Return Temperature: 40°C (104°F)

Fan Coil Wall Supply Air Temperature: 27°C (80.6°F)

	Medium Temperature (Airside)	High Temperature (Liquid Direct to Chip)
Total Block Load	13.74MW (3,906T)	102.4MW (29,120T)
Load Requirement/Chiller	2.75MW (781T)	2.93MW (832T)
Evaporator Flow Rate/Chiller	3,941 LPM (1,041 GPM)	4,200 LPM (1,109 GPM)
Facility Loop Temperature (Return)	32°C (89.6°F)	36°C (96.8°F)
Facility Loop Temperature (Supply)	22°C (71.6°F)	26°C (78.8°F)
Facility Loop Fluid	Water	Water
Max Ambient (Albuquerque, NM)	40°C (104°F)	
Elevation (Albuquerque, NM)	1,619m (5,312')	

DESIGN OVERVIEW

Reference Diagram

✓ Integrates air- and liquid-cooling systems

✓ Streamlined, low-complexity system - easy to commission

✓ Scalable, Future-Ready Solution

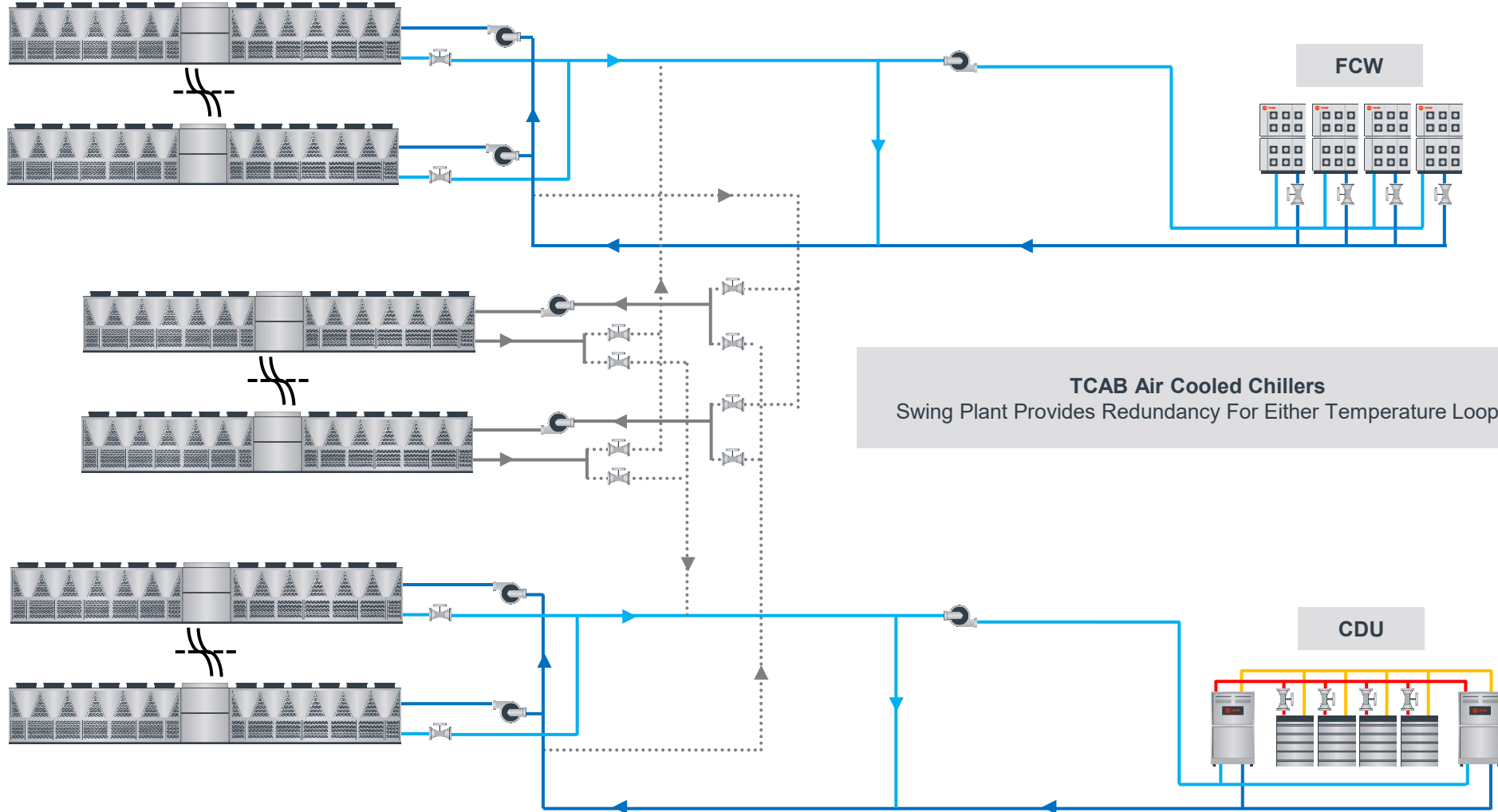

DESIGN OVERVIEW

Customer Outcomes



Reduce power use

- Dedicated high temperature loop reduces chiller power.
- Compressor assist economizer operation reduces chiller power off peak ambient temperatures.
- Advanced controls optimize chiller lift and pump energy to maintain best-in-class PUE.



Reduced Time to Full Performance

- Larger tonnage = fewer chillers to install, commission, and coordinate.
- Fully packaged air-cooled design requires no cooling towers or condenser-water systems.
- Factory-tested with integrated controls for minimal field commissioning.
- Simplified piping, electrical, and chilled-water connections reduce onsite labor.



Balanced total cost of ownership (TCO), redundancy and resiliency

- Swing chillers can serve high- or low-temperature loops, reducing the total chillers needed.
- Larger-capacity air-cooled packaged chillers reduce overall footprint.
- Magnetic-bearing technology reduces wear and maintains smooth modulation under load swings.

→ SYSTEM BENEFITS

Air-cooled chiller thermal management systems offer high efficiency and fully packaged solutions with the ability to be commissioned and scaled quickly. In addition, air-cooled chillers require no water and are simpler to operate in large-scale AI data centers.

- Reduced chiller footprint with higher-capacity 3MW air-cooled chillers
- Dedicated temperature loops improve the chiller efficiency of the high-temperature loop.
- Air-cooled chillers eliminate water use — Water Usage Effectiveness (WUE) = 0
- Low-GWP refrigerants R-1234ze significantly reduces carbon impact

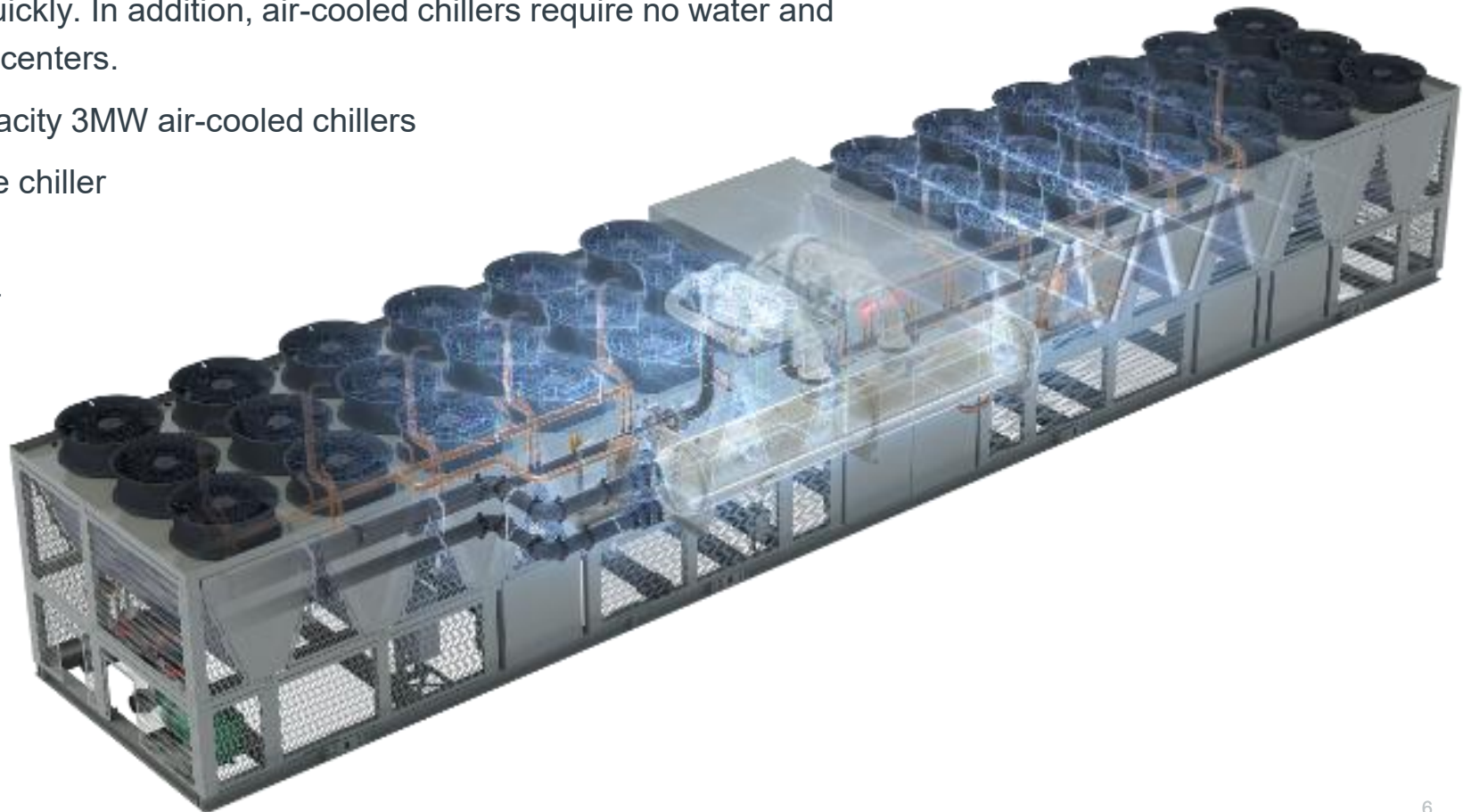

→ SYSTEM BENEFITS

Scalable and Simplified for Greater Efficiency

Dual-temperature chiller plant, dedicated medium and high temperature chillers

- Best used when load ratios and temperature requirements are well defined and stable.
- Separate loops eliminate unnecessary lift, allowing chillers to be selected and optimized specifically for each temperature band.
- Avoids the energy waste of single-temperature mixing strategies.

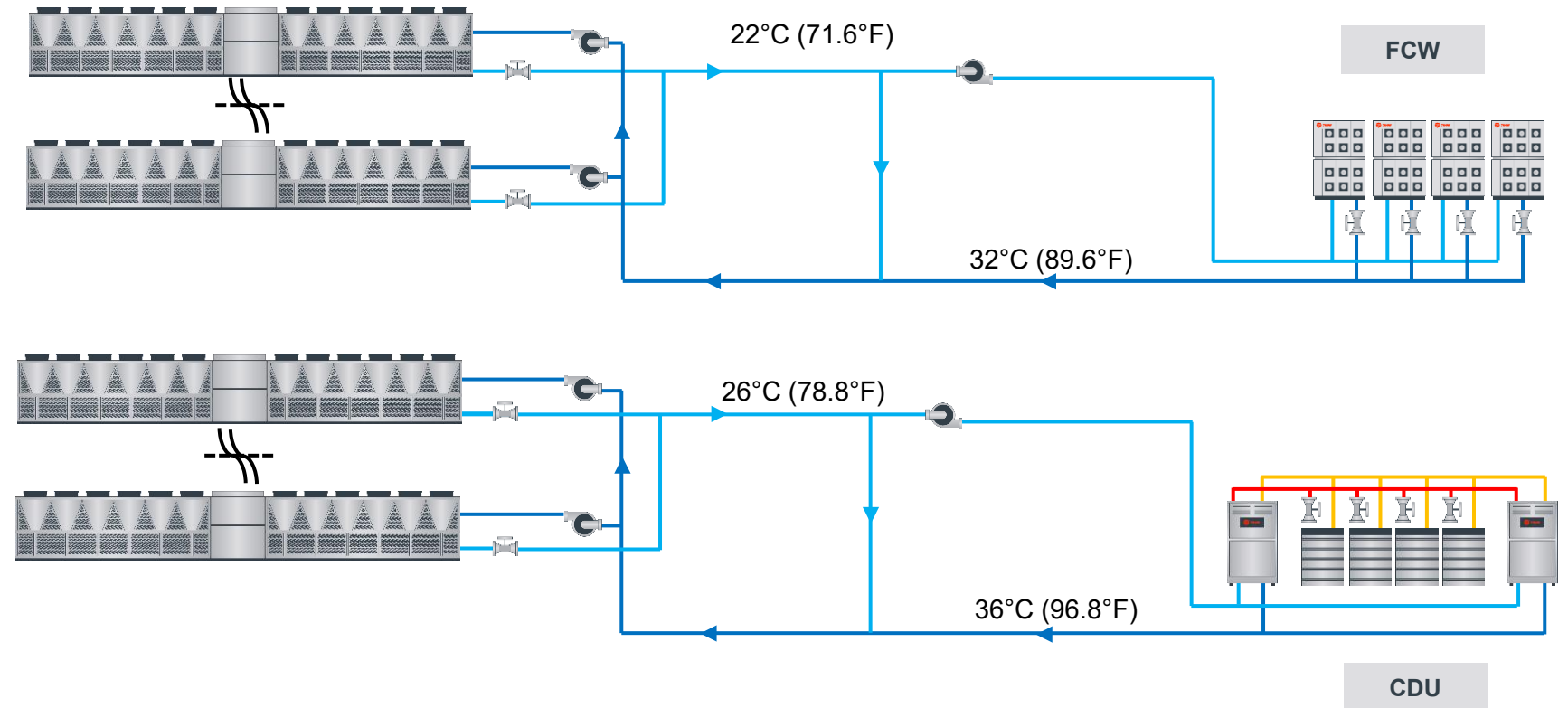

→ SYSTEM BENEFITS

Maximizes Token per Watt

Results of dedicated loops with higher temperature air-cooled chiller for liquid cooling on 1GW AI Factory:

- Baseline - single loop design feeding both FCW and CDUs at the same 22C (71.6F).
- Dedicated loops - load can be split with 93% going to higher 26C (78.8F) with much higher efficiency. 7% still at 22C FCW temp.

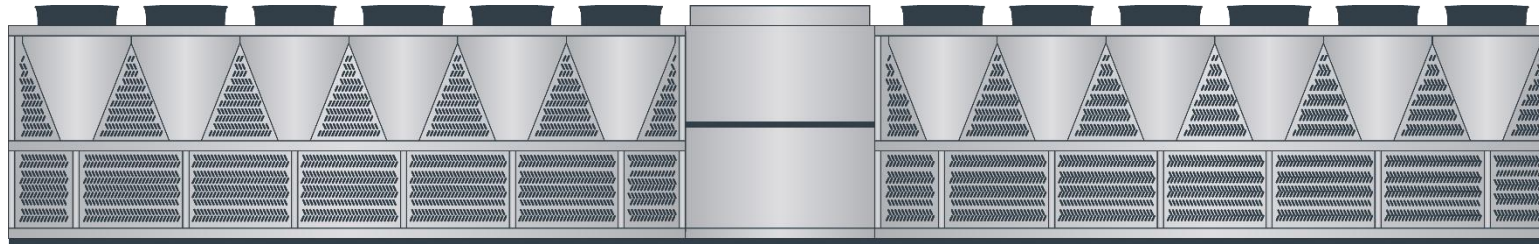

14%

Cooling system improvement

35MW

Available to reallocate

FULL LOAD - REDUCED LIFT OPERATION

TCAB “Compressor Assisted Economizer”

- TCAB chillers can run compressors at lower pressure ratios when conditions permit improving unit efficiency.
- Capacity is maintained while power consumption is reduced.
- Integrated controls enhance operation for reliable performance at low ambient conditions without reliance on glycol or free-cooling coils.

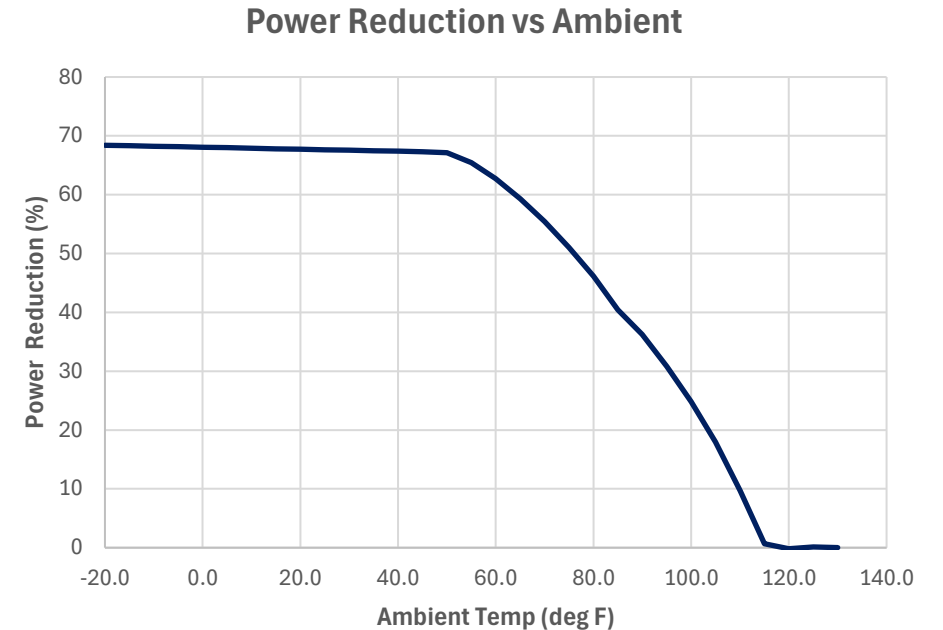

→ ENHANCED APPROACH

Design for Footprint or Efficiency

Design for Footprint Reduction – Peak Capacity

- Designing for the peak capacity for a given air-cooled unit allows for a minimized chiller plant footprint

Design for Efficiency – Below Peak Capacity

- For a given ambient temperature, limiting the capacity of an air-cooled unit reduces the condenser approach temperature, improving overall unit efficiency.
- Optimize according to your genset power allocation.

Operational Efficiency

- Utilize redundant chiller(s) and operate chiller array with each chiller at a lower capacity

Unit Capacity	System Efficiency	IT Cooling Power
Reduced	↑	↓
Max	—	—

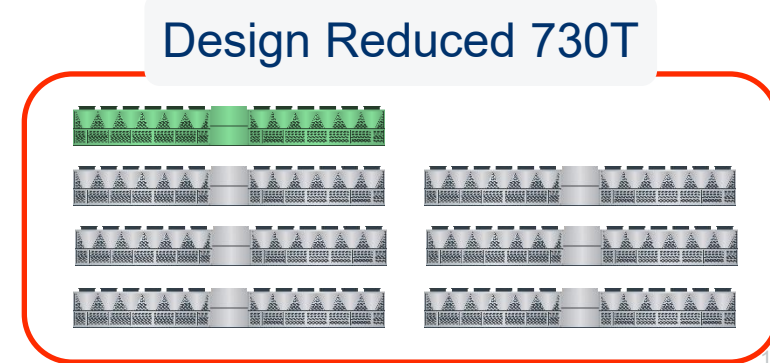
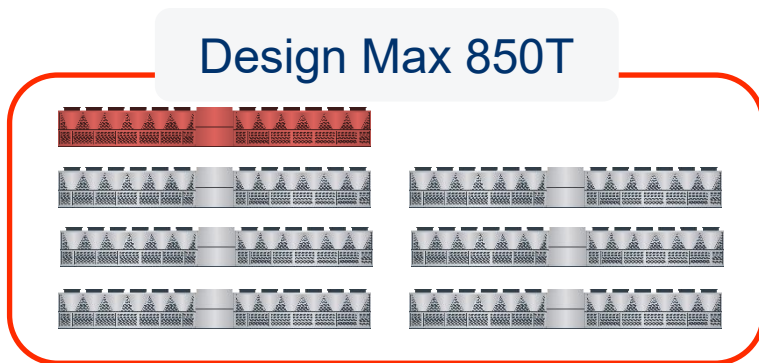
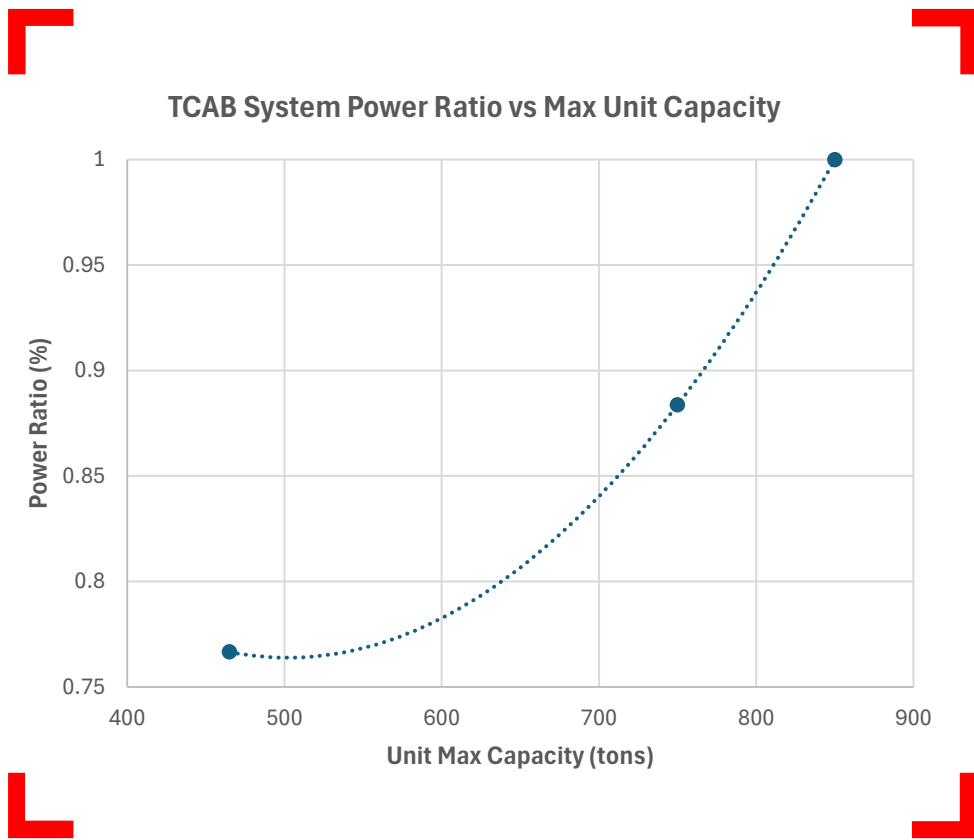

→ KEY SYSTEM COMPONENTS

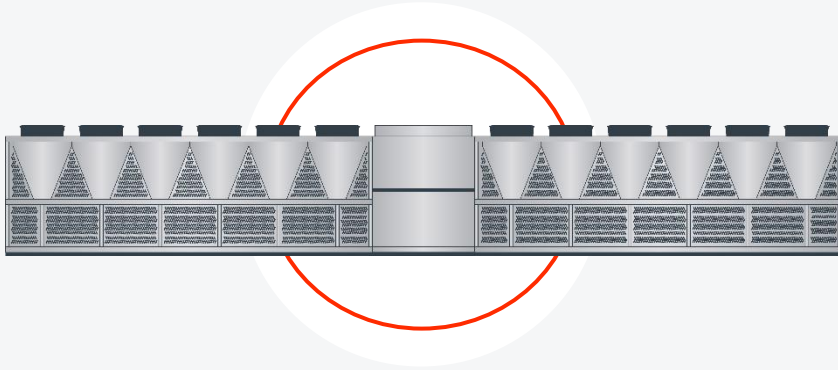

Air-Cooled Magnetic Bearing Chillers

Trane TCA Air-Cooled Magnetic Bearing Chiller delivers high-capacity, high-efficiency cooling engineered specifically for mission-critical data centers.

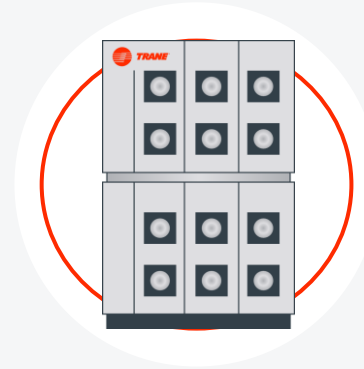

Fan Coil Walls

Trane Fan Coil Walls provide higher capacity, efficient air cooling in the data hall, using medium chilled-water temperatures to deliver added capacity where air cooling is needed most.



Coolant Distribution Units (CDUs)

Trane CDUs support the liquid-cooled portion of the data hall, separating facility and technical loops with a liquid-to-liquid heat exchanger for efficient, high-temperature cooling compatible with AI servers.



→ KEY SYSTEM COMPONENTS

Oil-Free Magnetic Bearing Air-Cooled Chiller Model TCA

Design Characteristic	Requirements
Capacity Range	Up to 850 tons (3+ MW)
Ambient Operation Range	-20 to 130°F (-29 to 54°C)
Facility Water Temperature Range	Up to 85°F (30°C)
Compressor	Oil free magnetic bearing two stage centrifugal compressor
Free Cooling Options	Compressor assisted economizer
Refrigerant	Low GWP: R-515B, R-1234ze
Restart After Power Loss	160 seconds @ 80% of full load
Power Feed Requirement	460, 3 ph, 60 Hz

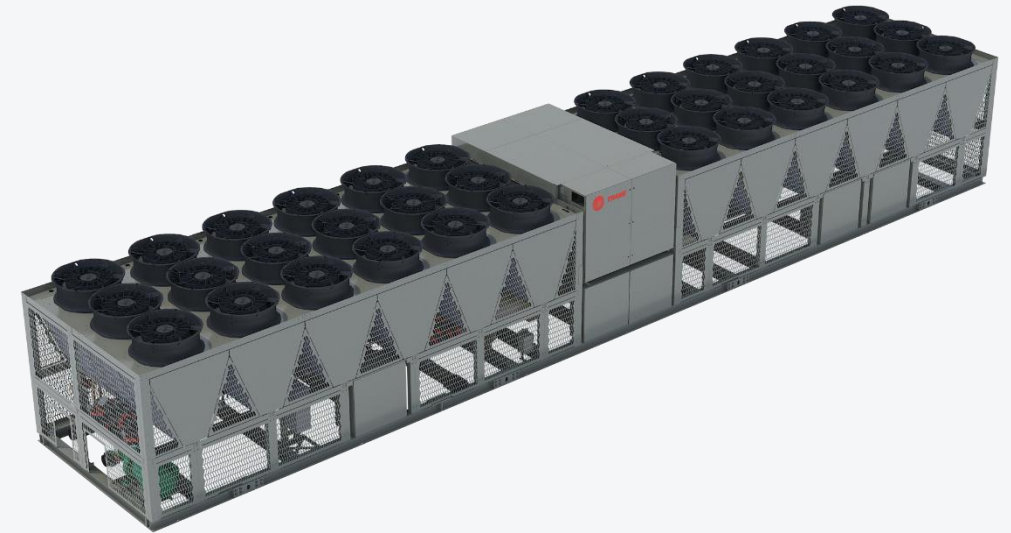

→ KEY SYSTEM COMPONENTS

Fan Coil Wall

Design Characteristic	Requirements
Capacity Range	Up to 800 KW
Airflow Range	110K CFM+
Entering Air Temp	Up to 40°C (104°F)
Fan Type	ECM Direct Drive Fans
Additional Feature Options	Automatic Transfer Switch Controller Capacitor Backup Controls Teaming Application Backdraft Dampers
Filtration	2" or 4" Filters (MERV 8 or 11)
Harmonic Filtration	5% or Less of Total Demand Distortion
Power Draw	< 6% of Capacity Being Cooled in KW
Power Feed Requirement	415-480, 3 ph, 50/60 Hz



→ KEY SYSTEM COMPONENTS

Coolant Distribution Unit (CDU)

Design Characteristic	Requirements
Capacity Range	Up to 14 MW at 4°C (7.2°F) Approach
Effectiveness	>90% at 4°C (7.2°F) Approach
Minimum Pressure Head	40 PSID + Pressure Drop Across CDU
Design Secondary (PG 25) Supply Temp	Up to 45°C (113°F)
Design Facility Water Temperature	Up to 41°C (105.8°F)
Max Ambient Temperature Operation	50°C (122°F)
Additional Feature Options	Scalable Solution Controls Teaming Application Pressure Independent Control Valve 316 Stainless Steel Plate Heat Exchanger Triple-Redundant Sensors in the Header
Secondary Side Filtration	25-Micron Filtration
Power Draw	< 2% of Capacity Being Cooled in KW
Power Feed Requirement	380-480, 3 ph, 50/60 Hz



→ KEY SYSTEM COMPONENTS

Computer Room Air Handler (CRAH)

Design Characteristic	Requirements
Capacity Range	50kW to 360kW to support varied density zones
Airflow Range	5,000 - 50,000k CFM
Fan Type	ECM Direct Drive Fans
Entering Air Temp	Up to 43°C (110°F)
Additional Feature Options	Automatic Transfer Switch (ATS) Controller Capacitor Backup Controls Teaming Application Condensate Pump Motorized return air damper
Filtration	2" (Merv 8 or 11) or 4" (Merv 8) Filters
Harmonic Filtration	5% or Less of Total Demand Distortion
Deployment Configuration	Downflow horizontal discharge for electrical room cooling Flexible for downflow white space use Optional upflow configuration
Power Feed Requirement	415-480, 3-phase, 60 Hz



→ BEST PRACTICES

Redundancy

Dual-temperature plant with swing chillers

A dual-temperature chiller plant with swing chillers allows redundant units to be flexibly assigned to either the high- or low-temperature loop, reducing the total number of chillers needed when full dual-loop redundancy isn't required.

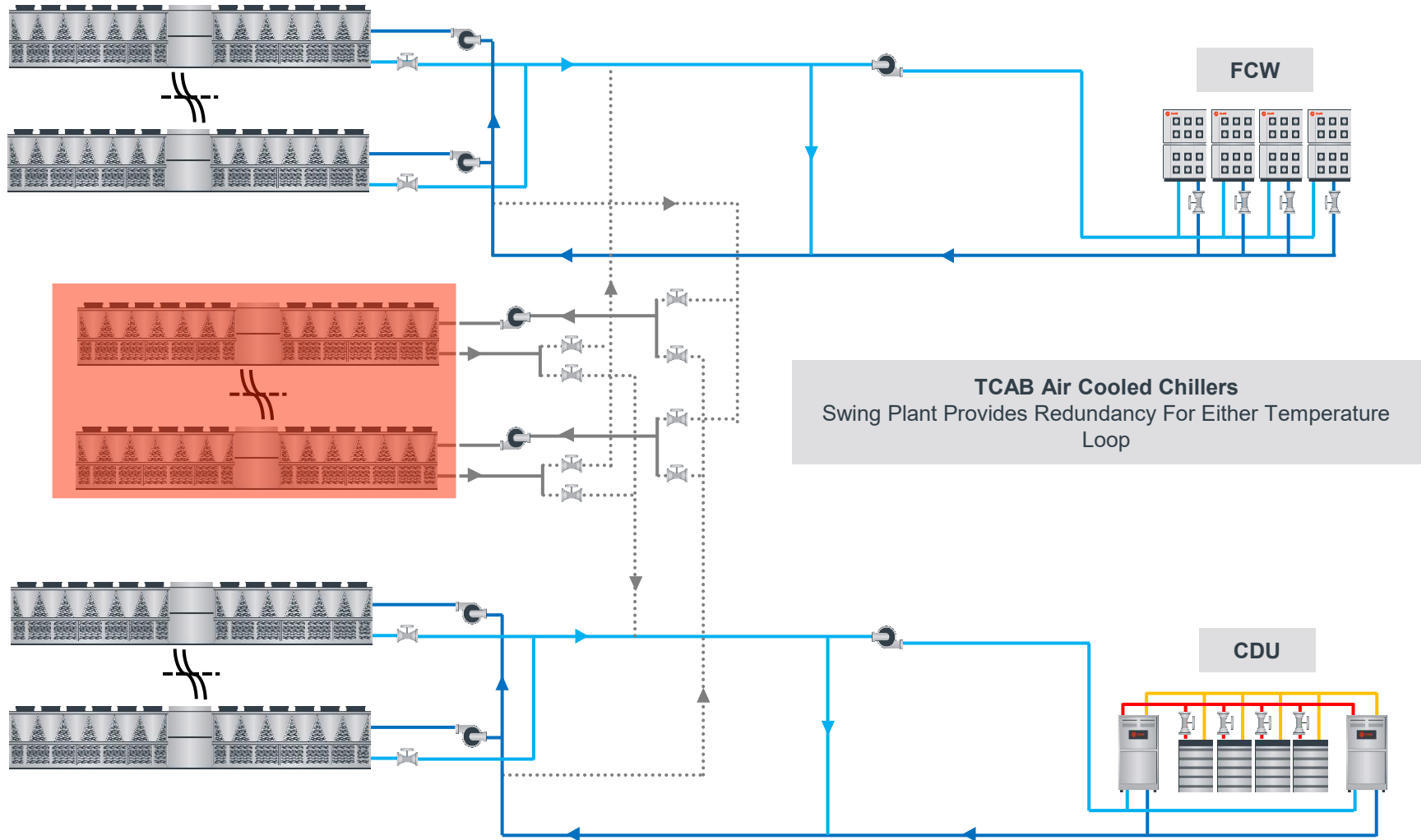

→ BEST PRACTICES

Freeze Protection

Outdoor equipment such as air-cooled chillers and exposed piping is at risk of freezing when ambient temperatures drop below the fluid's freeze point. Protection can be achieved by selecting a suitable fluid or by adding heat to maintain temperature above freezing.



Heaters

- Factory Installed
- Down to -20F
- Will not prevent refrigerant migration

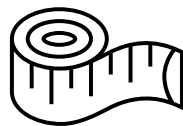

Heat Trace

- Install on all piping, pumps, and other water components exposed to ambient

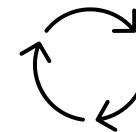

Flow Control

- Provided freeze avoidance for refrigerant migration (see p. 87 in [IOM](#))
- Must be provided without delay
- Meet minimum evap flow

*If chiller is to be isolated during flow control, included loop volume must be sufficient to prevent fluid from reaching it's freeze point.

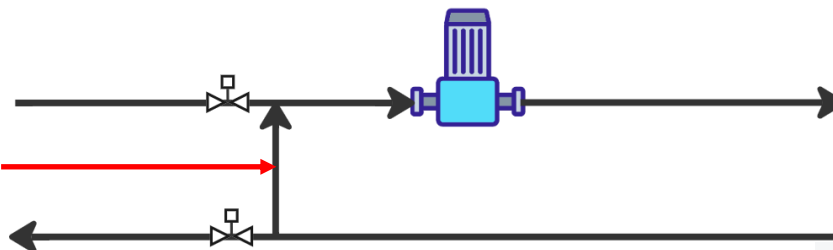

→ BEST PRACTICES

Thermal Energy Storage

Storage Location Matters

Thermal storage can be integrated into the chiller plant in several ways, with tank location determined by system needs.

- ✓ TES on FWS Supply
 - Provides capacity if the chiller plant is down
- ✓ TES on FWS Return
 - Smooths out chiller plant operation when compute loads fluctuate.
 - When installed on the return side, the tank helps buffer large temperature swings in return water during rapid load changes.
 - Stabilizing the return temperature enables chillers to maintain a consistent leaving-water temperature.
- ✓ TES on TCS Supply
 - Smooths out overall system operation and provides resiliency
 - UPS required for TCS loop only

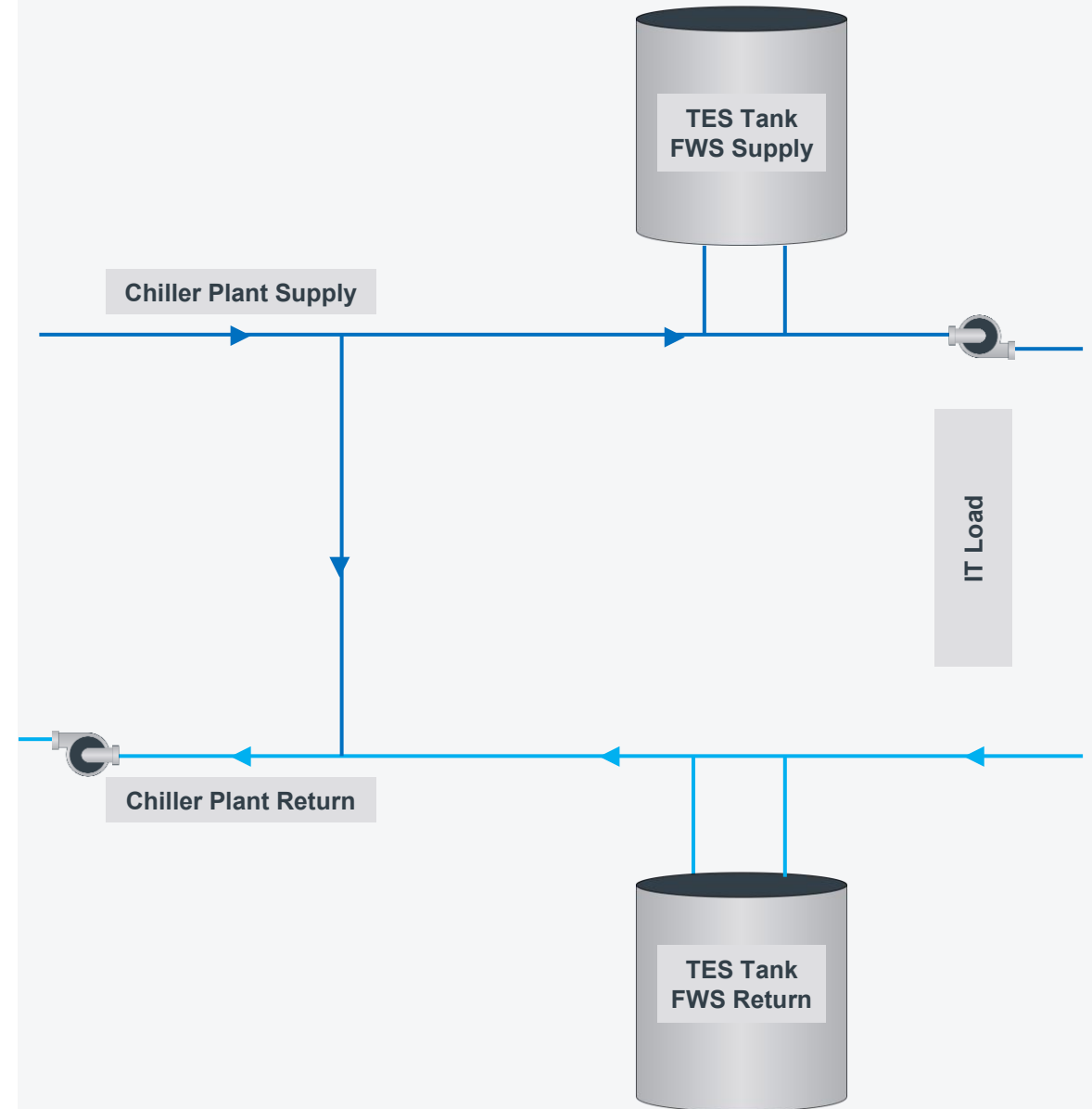

→ KEY SYSTEM COMPONENTS

Thermal Management Skid

Design Characteristic	Requirements
Capacity Range	1-3 MW (300-850 Tons) Custom sizes available Storage and flowrates adaptable to site specific requirements
Operating Modes	Freeze Avoidance Normal Operation Thermal Energy Discharge Thermal Energy Recharge
Pump	Variable Speed VFD
Other Accessories	Air Separator Bypass Piping Isolation Valves Control Panel
Commissioning	Full Function Testing with Tank and Chiller Possible.



→ BEST PRACTICES

Adiabatic Pre-Cooling

How It Works

- Air-cooled condenser performance depends on the temperature difference between refrigerant temperature and incoming dry-bulb air.
- Adiabatic cooling evaporates water into the inlet airstream, lowering effective dry-bulb temperature.
- Air temperature approaches wet-bulb, increasing heat-transfer capacity.
- Biggest gains occur in hot, dry climates with large DB–WB spreads.

Mechanical Cooling Benefits – Peak Shaving

- Boosts heat-rejection capacity during peak ambient temperatures.
- Reduces chiller lift and compressor power use.
- Allows for fewer quantity of units or reduced loading on existing units.
- Cuts compressor and fan energy during high-temperature periods.

- **Scenario 1:** Reduced Number of A/C Chillers
 - Lower first cost
 - Smaller footprint
- **Scenario 2:** Same Number of A/C Chillers
 - Reduced cooling power requirement
 - Lower sound with fan speed reduction
 - Resilience to micro-climate effect

→ BEST PRACTICES

Air-Cooled Chiller Plant Unloading Strategy

- Chiller efficiency improves as condenser approach temperature decreases (lower lift)
- Condenser approach temperature decreases as chiller capacity is reduced
- TCAB chiller has two 425-ton circuits
- When unloading from 850T to 425T, the chiller can either shut down one circuit or run both at ~50% load
- Running both circuits at partial capacity lowers condenser approach temperature and reduces total power use by ~33% compared to running a single circuit at full load
- With proper control of an air-cooled chiller array, this same concept can be applied to a group of air-cooled chillers connected to a common IT load

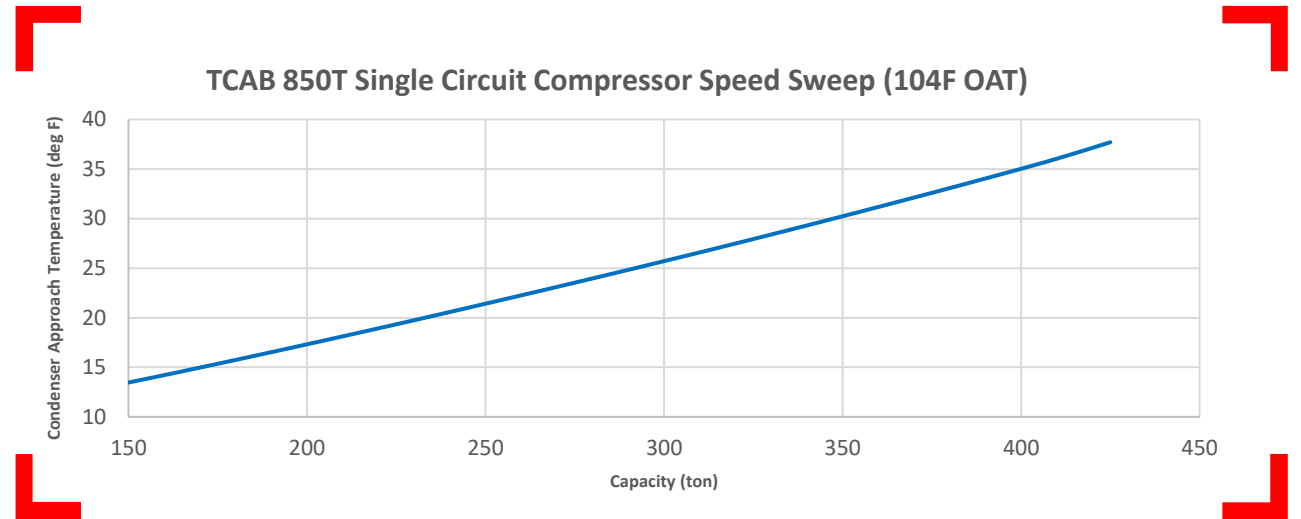

Load / Unload Chillers Sequentially

- Control Simplicity
- Can utilize fixed speed evaporator pumps
- Can rotate operating units for scheduled maintenance

Load / Unload Chillers Uniformly

- Maximize Efficiency (pPUE)
- Integrated controls required

*Qty of units operating will be selected to keep running units above min capacity

→ **SYSTEM CONTROLS**

Effective controls are critical to chiller plant performance and reliability. Trane's data center–tailored control platform promotes efficiency, uptime and responsiveness by integrating all major components — chillers, dry coolers, pumps, valves, CDUs and fan coil walls — into one coordinated system.



SYSTEM CONTROLS

Reference Diagram

System Control

Tracer® is a unified thermal management system that simplifies operations by handling chiller rotation, staging, and sequencing with built-in tools that boost reliability and enable data-driven performance.

AI Enhancements

Take optimization further with our AI-driven efficiency engine. **Trane® AI Control** blends decades of expertise with real-time data to continuously improve your thermal management system and capture every possible watt of savings.

Trane Thermal Management System

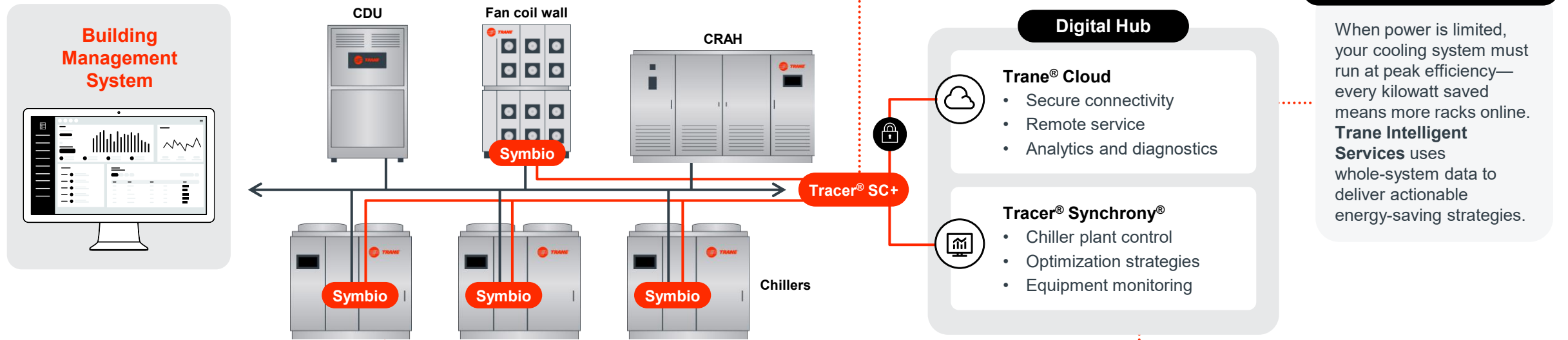

Insights + Optimization

When power is limited, your cooling system must run at peak efficiency—every kilowatt saved means more racks online. **Trane Intelligent Services** uses whole-system data to deliver actionable energy-saving strategies.

Equipment Connectivity

Symbio® controls collect and translate key equipment data into the **Tracer SC+**, enabling data-driven service and optimization.

Predictive Maintenance

With your permission, we can securely connect to your equipment or Tracer SC+ to enable **Connected Mechanical Service**. By monitoring trends and performance data, we help identify issues early so your team or our technicians can act before failures occur. And when on-site support is needed, **Trane Service Agreements** and **local technicians** are ready to respond.



TRANE SERVICE

As data centers expand in size and complexity, the need for dependable, efficient cooling grows with them. Trane's thermal management services are designed to meet these evolving demands — providing scalable, responsive support that adapts to changing loads, tighter schedules and zero-tolerance uptime requirements.

- Embedded expertise helps support reliable operation from design through expansion and refresh
- Proactive planning helps reduce risk and downtime
- Connected insights help optimize capacity and efficiency across the lifecycle



→ TRANE RENTAL SERVICES

Need unrivaled temporary thermal management and power solutions for your data center? Trust Trane Rental Services for:

- Level 2, 3, and 4 **commissioning services**, including line flushes and load bank testing
- **Expansion and retrofits** for new chip designs
- Planned **maintenance, emergency response, and redundancy** to protect SLAs
- Overcoming **new equipment lead times** to speed up new facility launches

As one of North America's largest OEM HVAC rental companies, Trane Rental Services leads the market. Our highly trained staff, rapid emergency response, and unmatched expertise are supported by 150 locations, 230 parts centers, and 2,600 technicians. Choose Trane Rental Services for reliable, expert solutions.

[Trane.com/rentals](https://www.trane.com/rentals)

1-800-755-5115



→ DESIGN RESOURCES

Trane provides a complete suite of resources to support the design of high-performance thermal management systems for data centers.

- All mechanical components are selected for site-specific conditions, with detailed submittal packages available
- System control sequences and operating modes can be customized for any chiller plant configuration
- TRACE® modeling tools evaluate annual energy performance and efficiency
- Application guides and Trane experts are available to assist with design, optimization and implementation

Reach out to Trane today for more information.





HELPFUL LINKS

Trane BIM and Selection Tools →

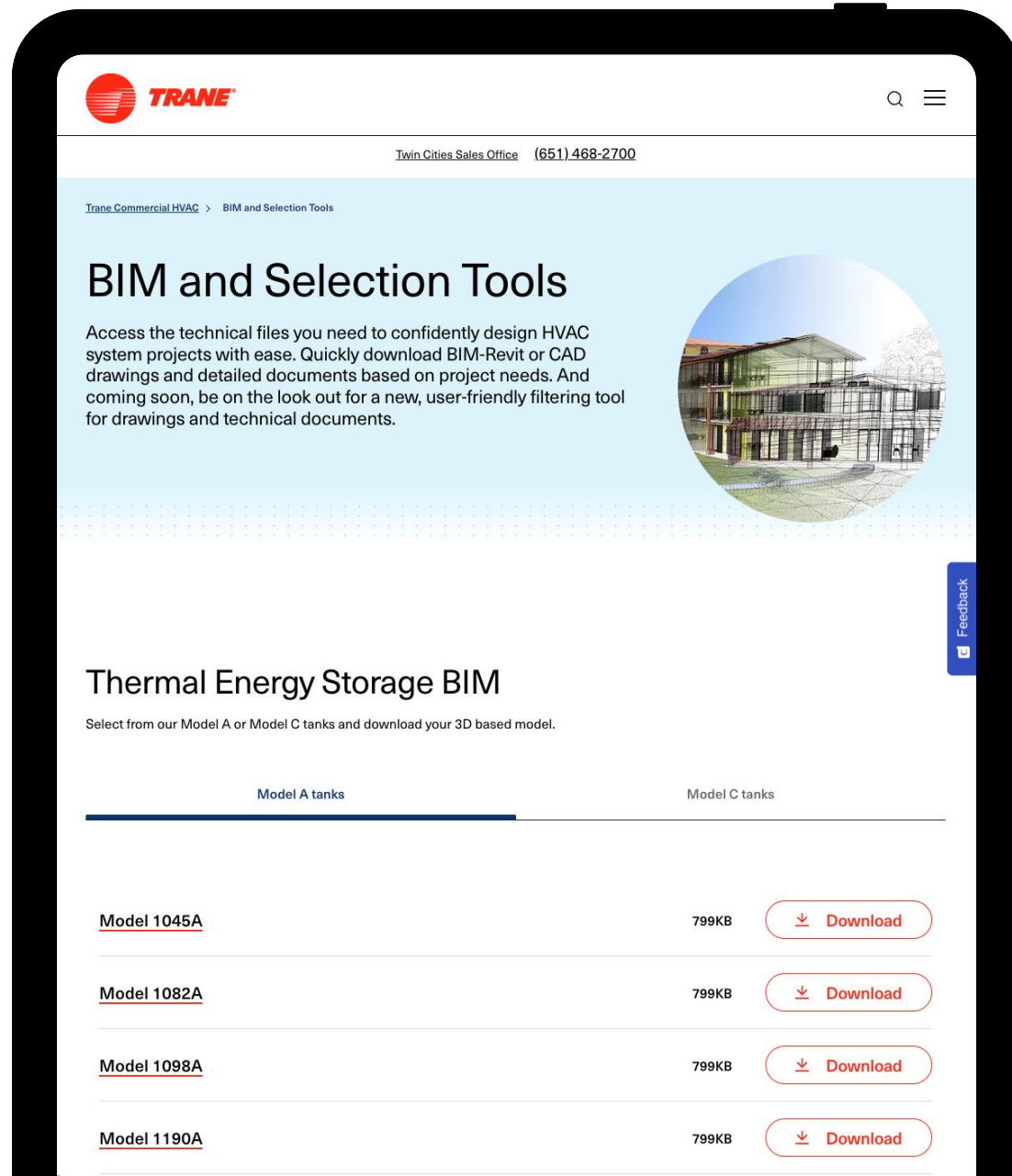

Trane.com/DataCenters

This is for informational purposes only and does not constitute professional advice. Trane believes the facts and suggestions presented here to be accurate; however, final design and application decisions are your responsibility. Trane disclaims any responsibility for actions taken on the material presented.



Trane – by Trane Technologies (NYSE: TT), a global climate innovator – creates comfortable, energy efficient indoor environments through a broad portfolio of heating, ventilating and air conditioning systems and controls, services, parts and supply. For more information, please visit trane.com or tranetechnologies.com.

All trademarks referenced in this document are the trademarks of their respective owners. © 2025 Trane. All Rights Reserved.

DC-PRR006B-EN
05/27/2026